



**MONTERINGSANVISNING · INSTALLATION INSTRUCTIONS  
MONTAGEANLEITUNG · INSTRUCTIONS DE MONTAGE**

**Saab 9-3 M03-**

**Mudflaps, rear**

Accessories Part No.	Group	Date	Instruction Part No.	Replaces
12 786 785	9:84-20	Aug 02	12 798 022	12 798 022 May 02

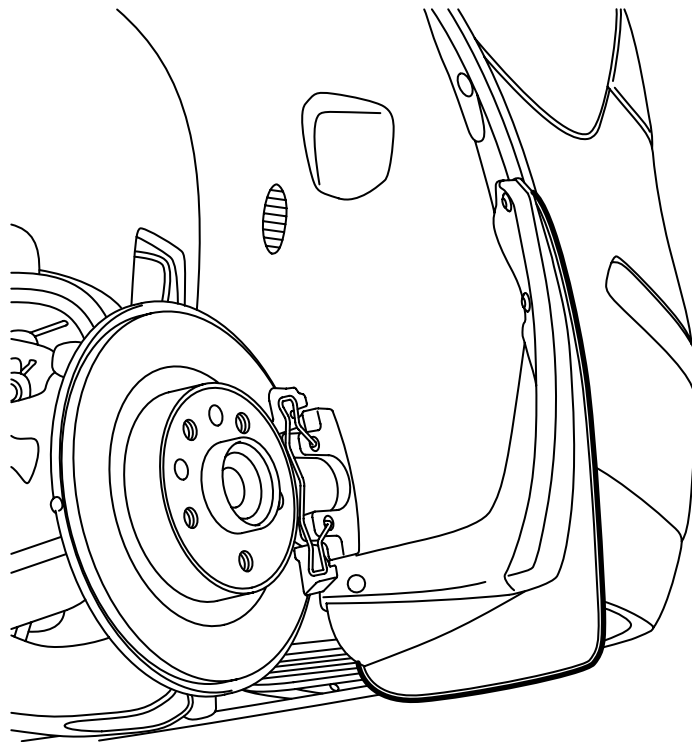

F980A153

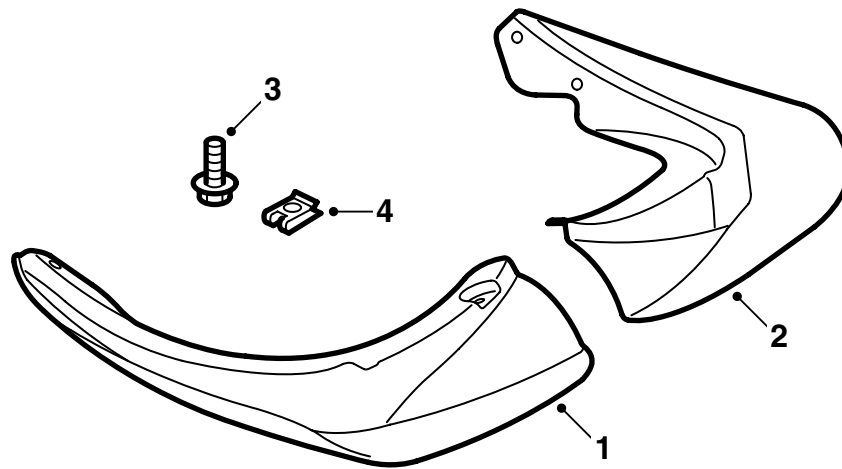

F980A154

- 1 Mudflap L
- 2 Mudflap R
- 3 Screw (x8)
- 4 Clip nut (x4)

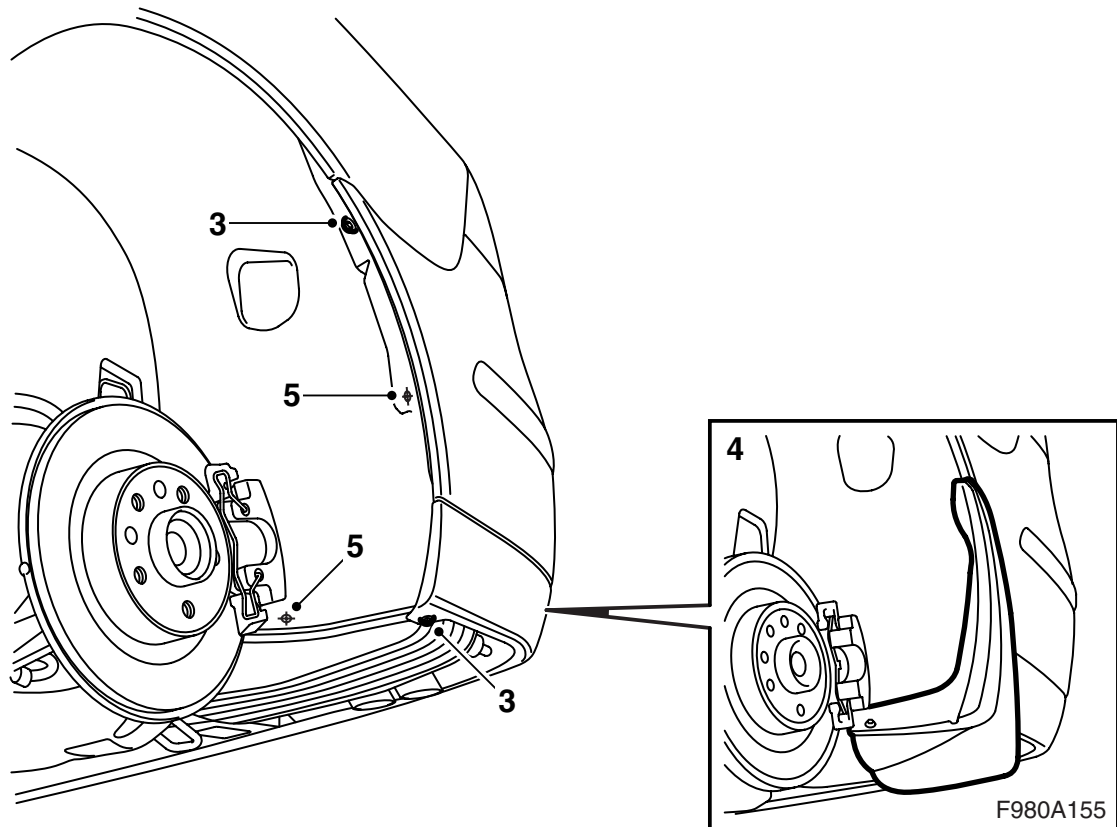

- 1 Raise the car.
- 2 Remove both rear wheels.
- 3 **Left-hand side:** Remove the bolt mounted underneath and the lower edge of the wheel housing.
- 4 **Left-hand side:** Fit the mudflap against the wing liner. Use the mudflap as a drilling template.

---

### Important

Do not apply pressure as that could damage the wing liner.

- 
- 5 **Left-hand side:** Use a 6 mm bit to drill 2 holes to match the holes in the mudflap and then put the mudflap aside.

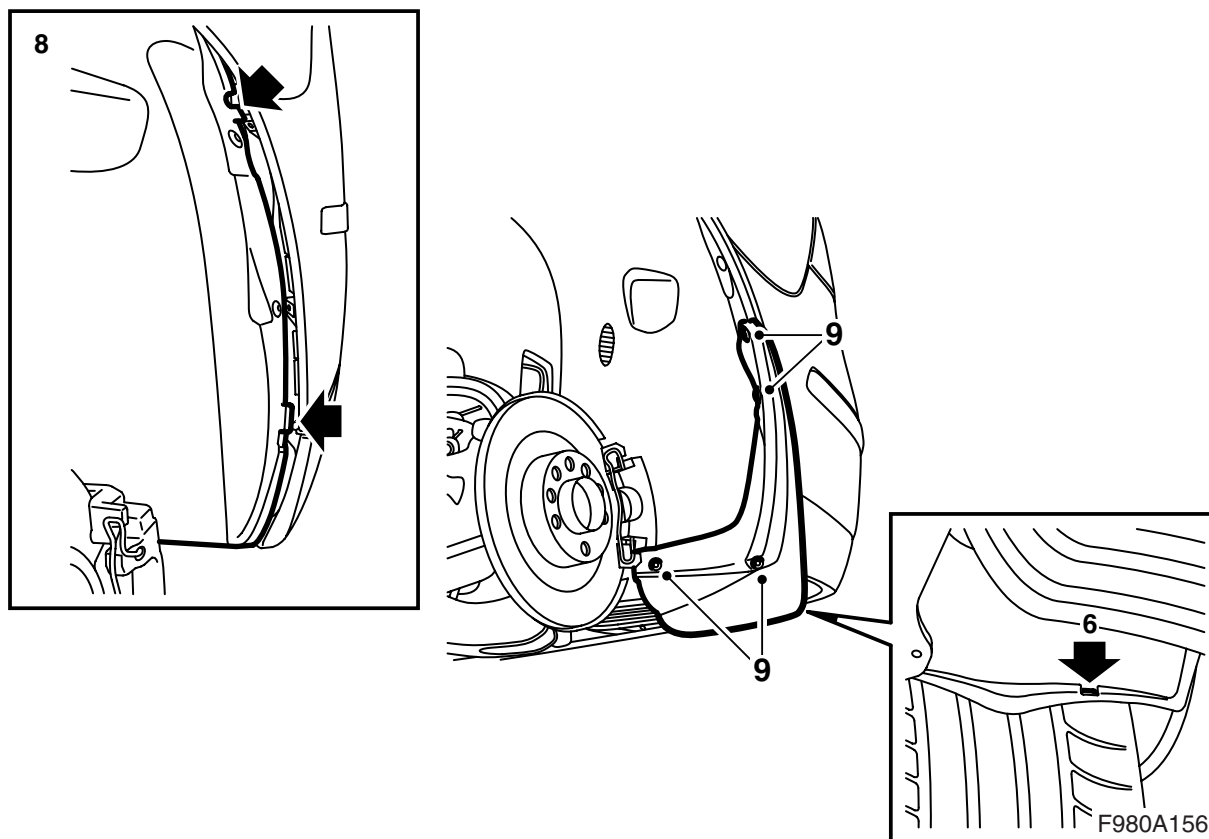

- 6 **Left-hand side:** Use a knife to make a groove from underneath where the lower clip nut shall be fitted (the location is illustrated looking from the back of the wing liner).
- 7 **Left-hand side:** Carefully prise out the wing liner and fit the clip nuts.
- 8 **Left-hand side:** Refit the wing liner.
- 9 **Left-hand side:** Fit the mudflap. Check the fit against the bumper and adjust as necessary.

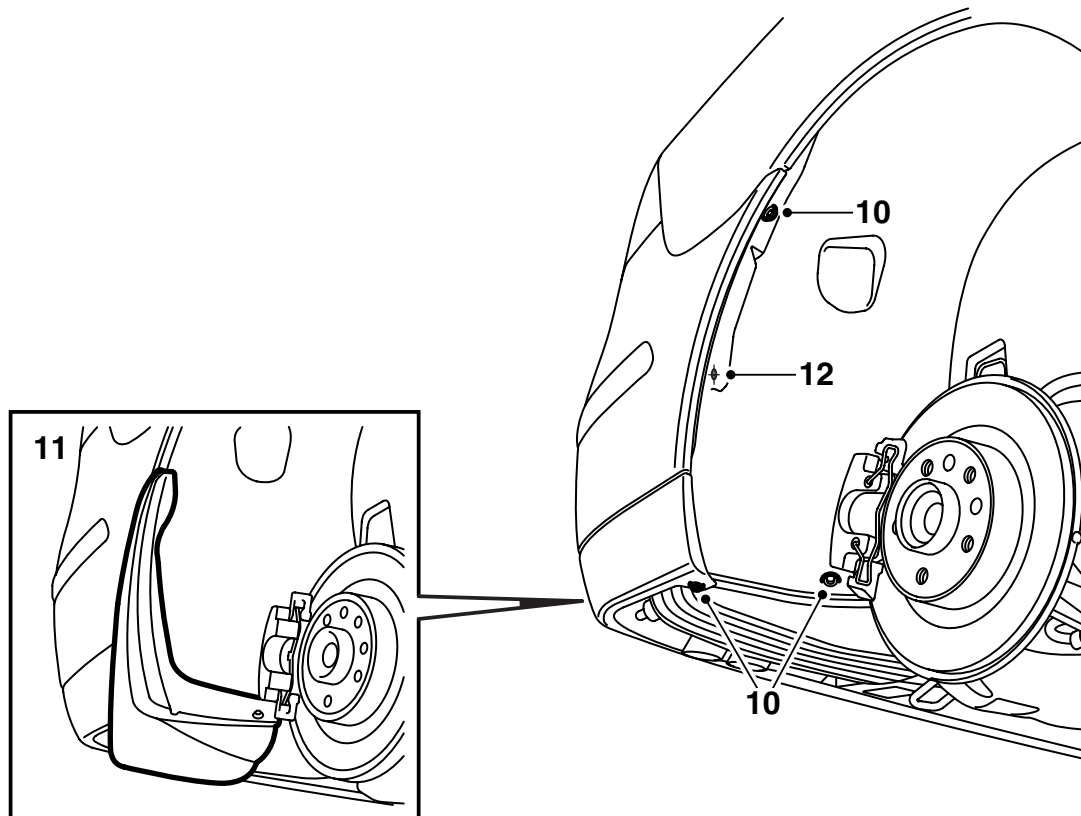

F980A157

- 10 **Right-hand side:** Remove the bolt mounted underneath, the lower edge of the wheel housing and the bolt located in the rear edge of the wing liner.
- 11 **Right-hand side:** Fit the mudflap against the wing liner. Use the mudflap as a drilling template.

### Important

Do not apply pressure as that could damage the wing liner.

- 12 **Right-hand side:** Use a 6 mm bit to drill holes to match the holes in the mudflap and then put the mudflap aside.
- 13 **Right-hand side:** Carefully prise out the wing liner and fit the clip nuts.

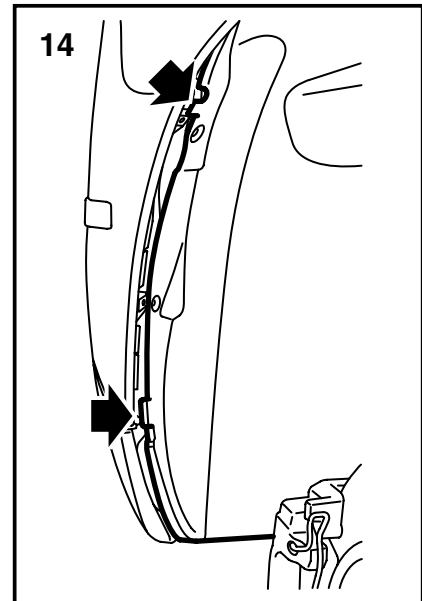
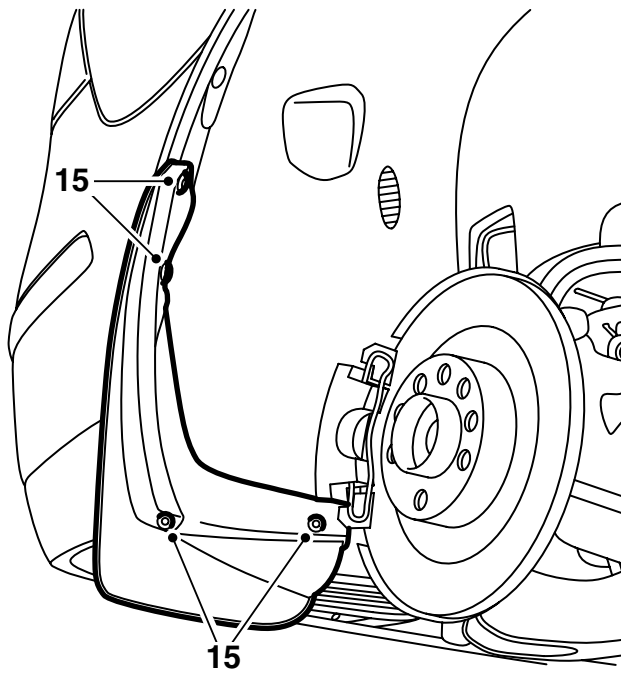

F980A158

- 14 **Right-hand side:** Refit the wing liner.
- 15 **Right-hand side:** Fit the mudflap. Check the fit against the bumper and adjust as necessary.

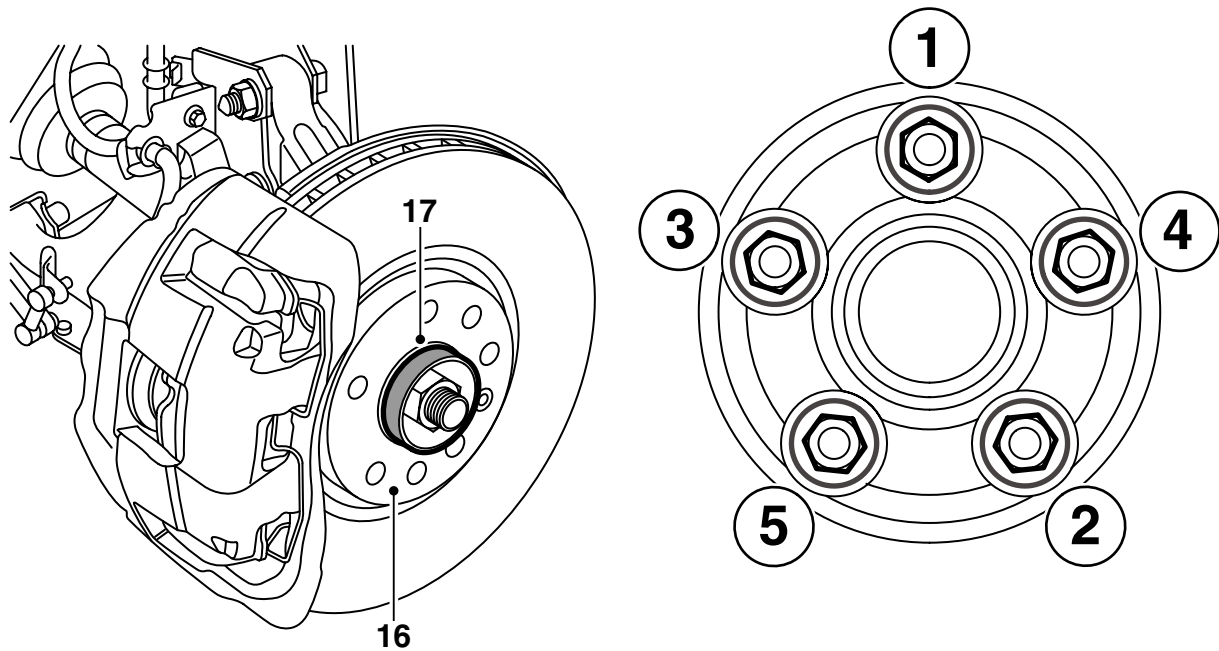

F980A159

- 16 Clean all dirt and rust from the contact surfaces of the wheel and brake disc.
- 17 Apply white high-pressure grease (part no. 30 06 442) to the hub.

---

**Important**

Make sure that no grease gets onto the contact surfaces of the wheel and brake disc.

- 
- 18 **Aluminium wheels:** Oil the bolt threads and the conical surface of the bolts.
- 19 Position the wheel, fit the bolts and tighten these in sequence by hand to centre the wheel.
- 20 Tighten the bolts in sequence twice.

---

**Important**

The wheel should be freely suspended during tightening.

---

**Tightening torque 110 Nm (81 lbf ft)**

- 21 Repeat steps 16-20 on the right-hand side of the car.
- 22 Lower the car.