



**MONTERINGSANVISNING · INSTALLATION INSTRUCTIONS  
MONTAGEANLEITUNG · INSTRUCTIONS DE MONTAGE**

**Saab 9-3, Saab 9-5**

Canoe/kayak carrier

Accessories Part No.	Group	Date	Instruction Part No.	Replaces
12 791 387 400 132 312	9:89-07	Apr 02	12 792 695 (55 20 887)	

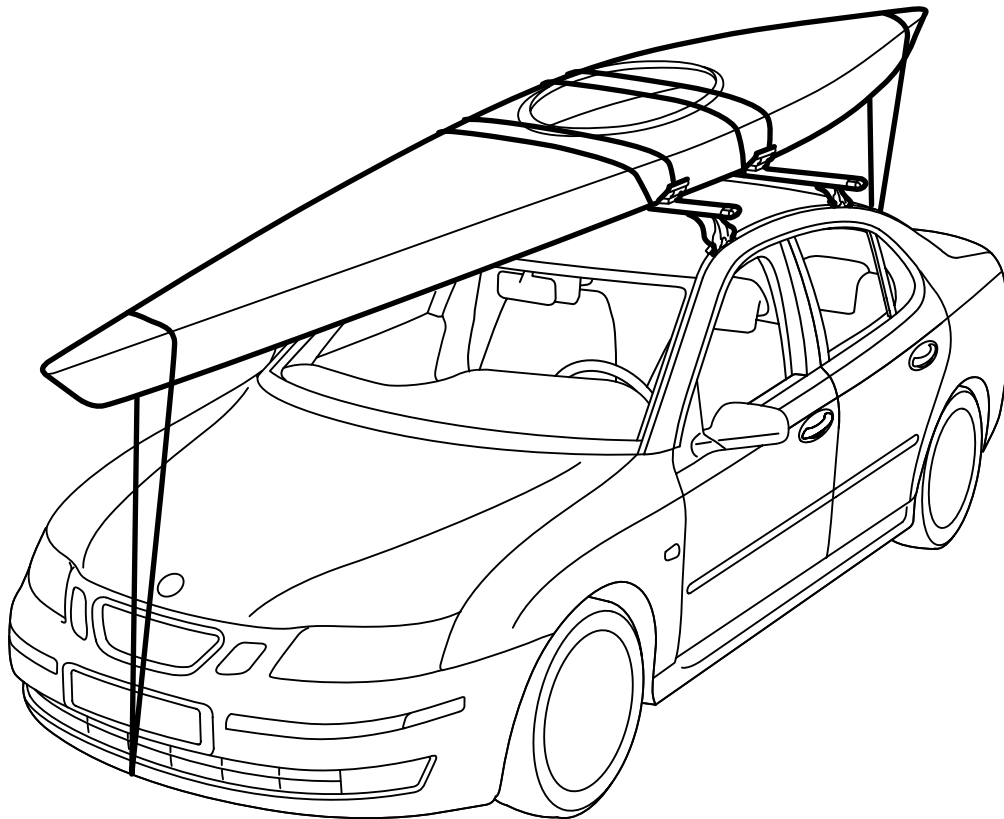

F980A077

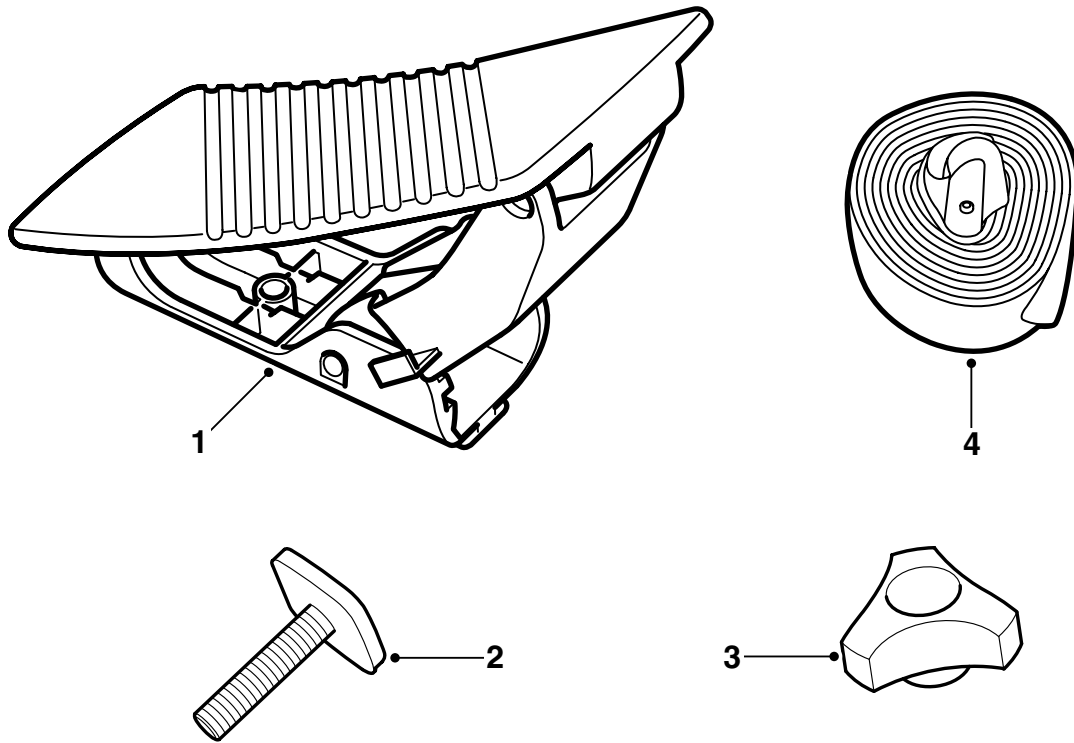

F980A078

- 1 Holder (x4)
- 2 T-groove bolt (x4)
- 3 Wheel nut (x4)
- 4 Strap (x2)

## Important

 **WARNING**

Read the installation instructions carefully before using the canoe/kayak carrier. Carefully follow these instructions when fitting the canoe/kayak carrier and keep them in the car for future reference.

Adapt the speed of the car to take into account the change in centre of gravity and aerodynamics caused by the weight and profile of the roof load.

- Do not fit or use the carriers until these installation instructions are fully understood.
- The carriers are constructed for safe transport provided that they have been properly mounted.  
**Product modifications must not be made.**
- The heaviest permitted roof load is 100 kg (220 lbs.) including the load carrier weight: 3.9 kg (8.6 lbs.) (steel), 4.7 kg (10.4 lbs.) (aluminium) and canoe/kayak carrier weight: 2.5 kg (5.5 lbs.). See the Owner's Manual.
- Note that the car's handling characteristics (during strong crosswinds, cornering or braking) are altered while driving with a loaded carrier.
- For safety reasons and to reduce wind resistance, the carriers should be removed when not in use.
- The load carrier should be removed before the car is taken through an automatic car wash.
- Saab Automobile AB is not responsible for damages caused by improperly mounted load carriers or accessories.
- When in doubt, contact your Saab dealer.
- These installation instructions should be stored in the car.

## Advice and tips

- No modifications should be made to the carriers.
- Secure the load so that it cannot loosen or cause damage. Be sure to tie down the load so that it cannot move in any direction. The driver is responsible for ensuring that the load is properly secured.
- Be sure to distribute the load weight equally on the carriers.
- Long objects must be braced or secured to the bumper or the towing eye both front and rear. If the load extends more than 1 m (3.3 ft) to the rear of the car or if it extends over the front of the car, it must be properly marked with warning flags or the like.
- The carriers may only be used for transporting canoes or kayaks.
- Make sure all fasteners are secured before driving off. Stop after a short distance and check all the fasteners.
- Keep the carriers free from dirt and salt and perform regular maintenance.

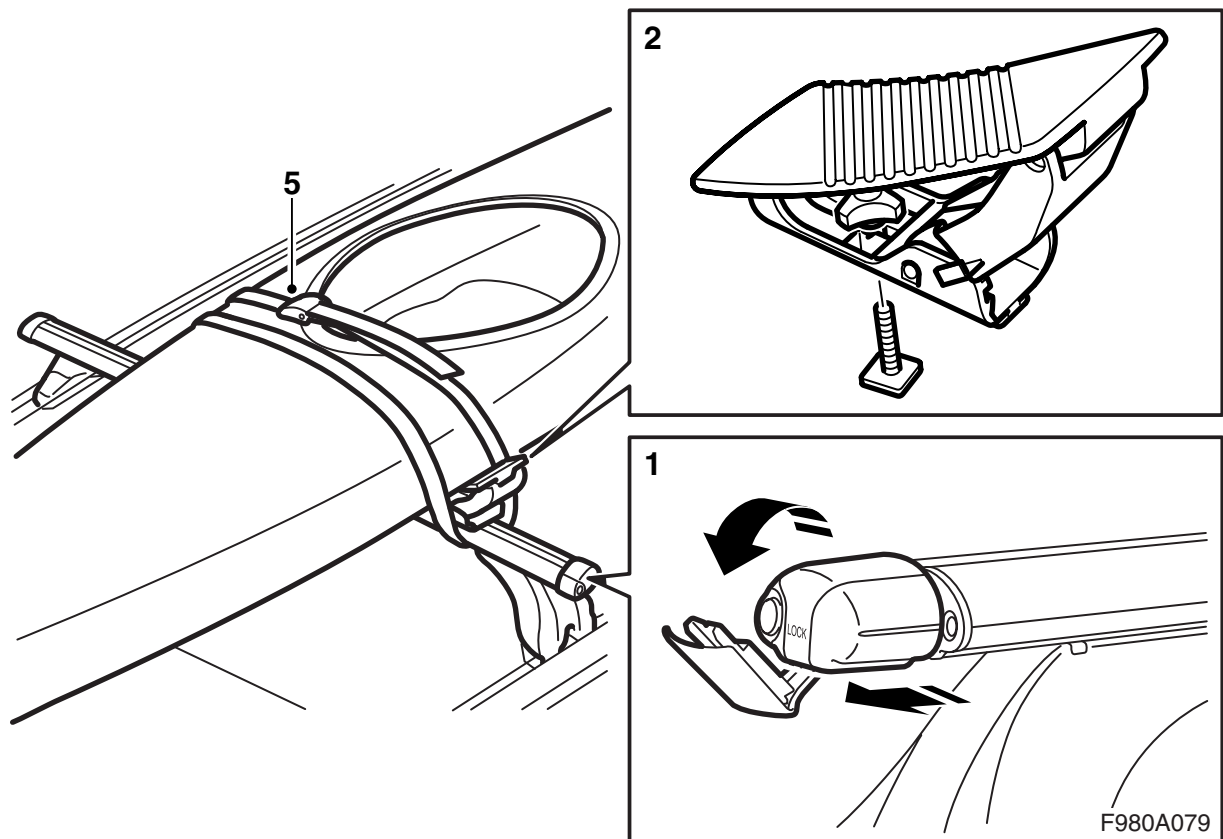

- 1 Pull out the load carrier end plugs and fold down the centre section.
- 2 Mount the carriers together with the T-groove bolt and wheel nut.
- 3 Insert canoe/kayak holders into the load carrier grooves. Tighten the wheel nuts when the canoe/kayak holders are properly positioned.
- 4 Fold up the centre section of the load carrier end plugs and insert the end plugs.
- 5 Secure the canoe/kayak with the straps.
- 6 Adjust the holder angle by pressing in the catch and moving the outer part of the holder up or down.

These installation instructions should be stored in the car.