



**MONTERINGSANVISNING · INSTALLATION INSTRUCTIONS
MONTAGEANLEITUNG · INSTRUCTIONS DE MONTAGE**

Saab 9-3 M03-

Wiring harness, spotlights

Accessories Part No.	Group	Date	Instruction Part No.	Replaces
12 787 159	9:37-04	Feb 03	12 788 440	12 788 440 Oct 02

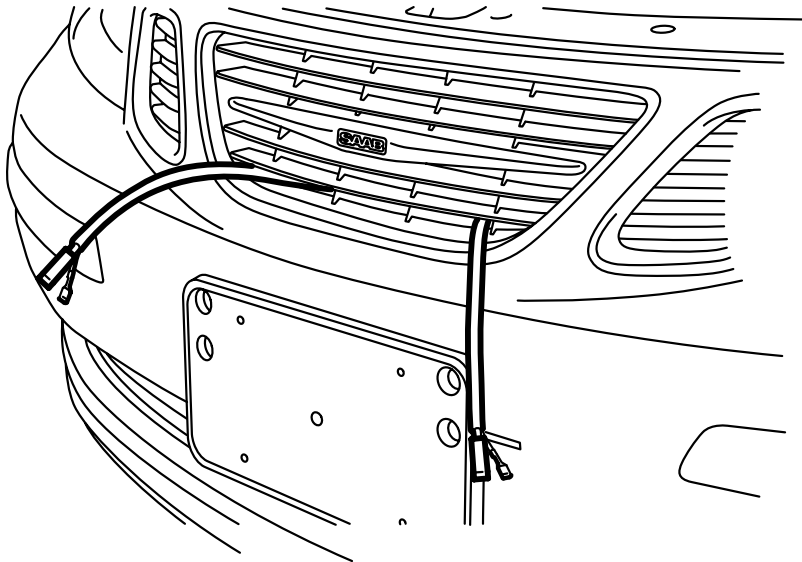

F930A041

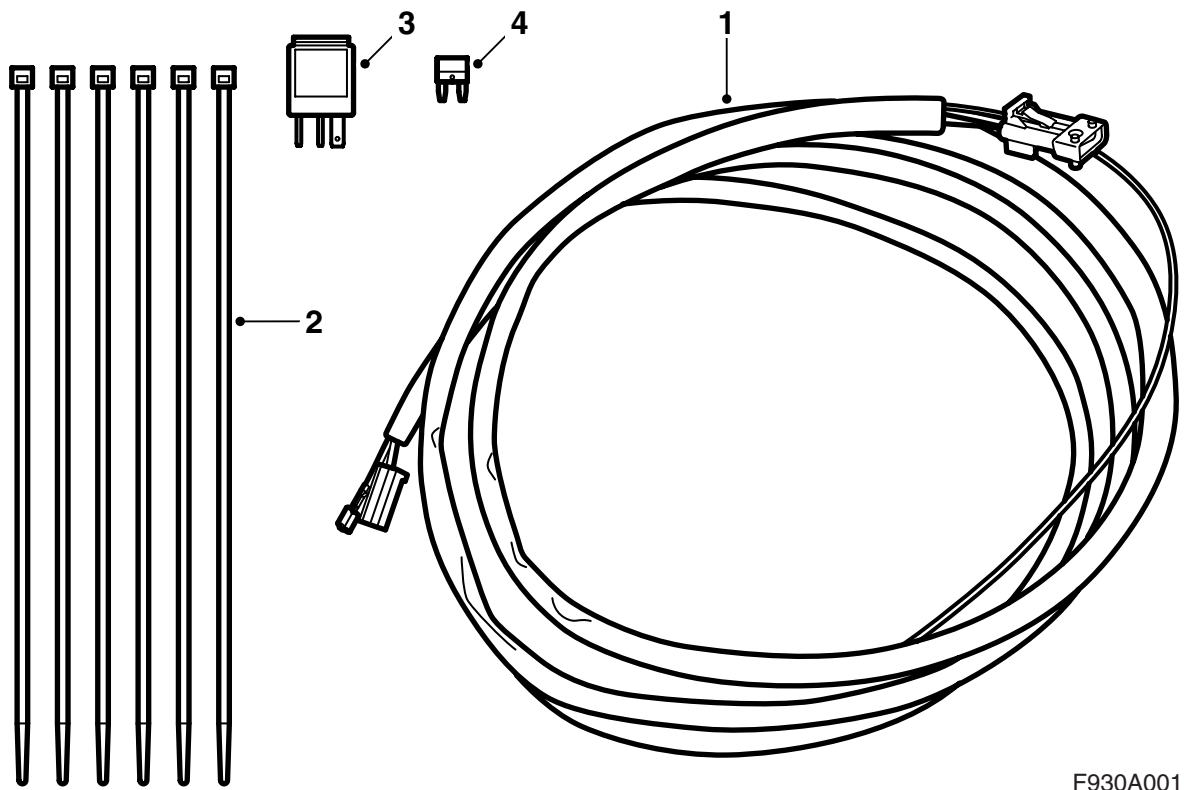

F930A001

- 1 Wiring harness
- 2 Cable tie (x6)
- 3 Relay
- 4 Fuse 15A

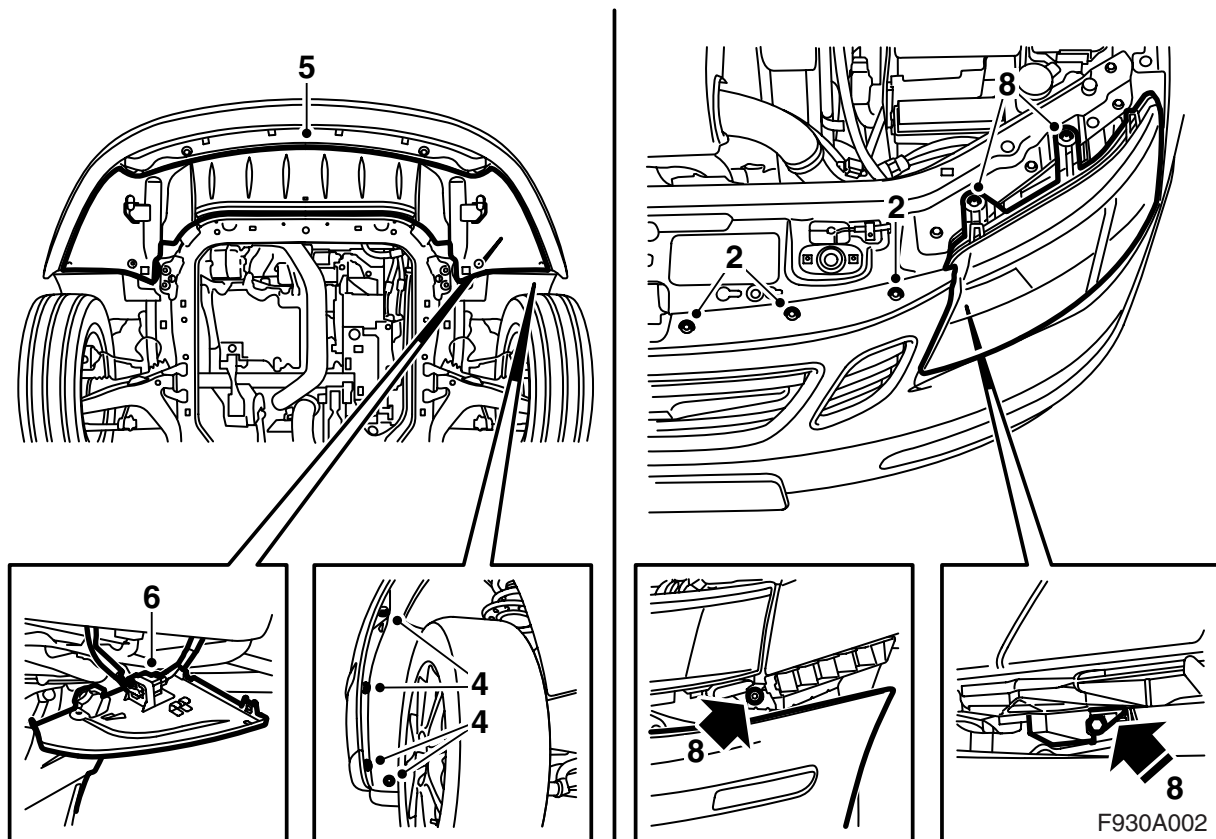

- 1 Disconnect the negative battery cable.
- 2 Remove the bumper shell clip from the upper radiator member.
- 3 Raise the car.
- 4 Remove the bumper bolt in the wheel housing.
- 5 Remove the spoiler shield.
- 6 Unplug the bumper connector and remove it from the holder on the spoiler shield.

Cars with headlamp washers: Unhook the hose from the spoiler shield.

- 7 Pull out the bumper shell side pieces and remove the bumper.

Cars with headlamp washers: Detach the hose from the branching piece and plug the hose with an 8.5 mm drill.

- 8 Remove the left-hand headlamp.

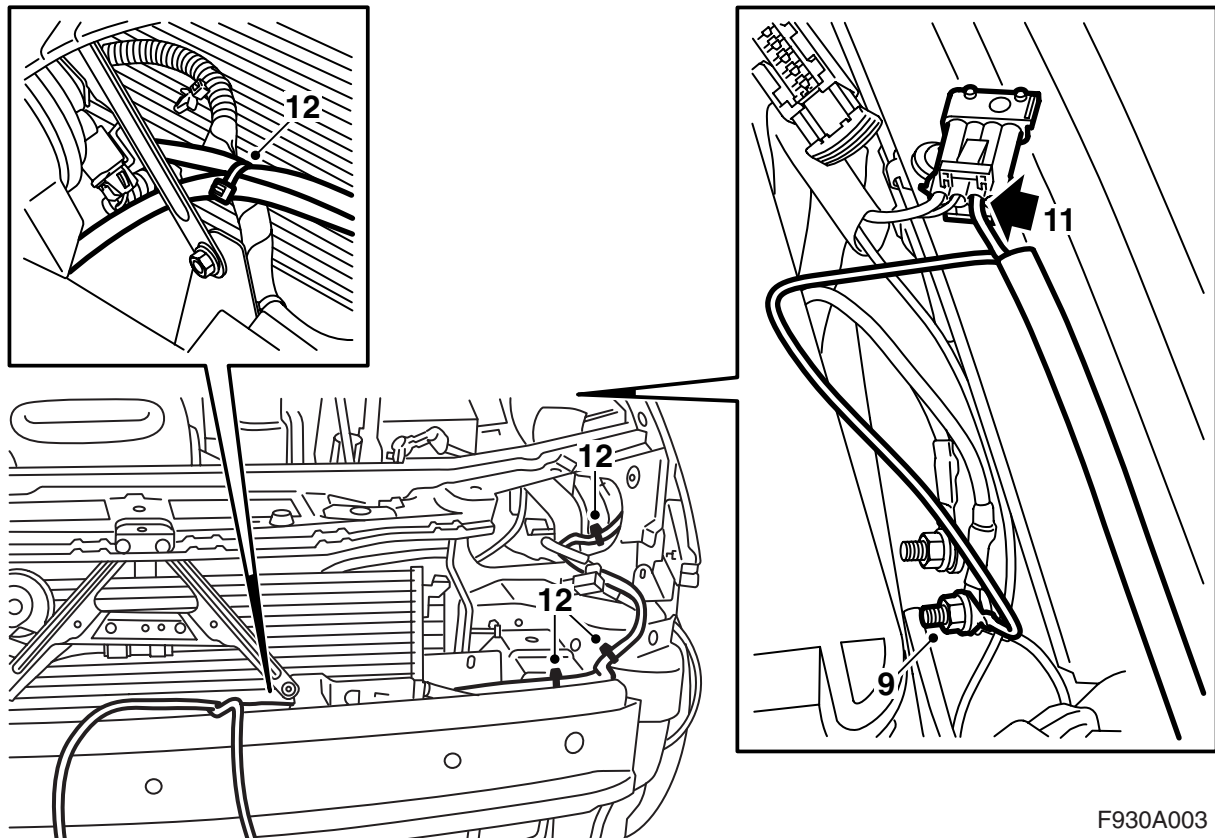

F930A003

- 9 Connect the ground cable to the front grounding point (G30A) in the engine bay main fuse box.
- 10 Locate the "Pre Acc" outlet between the engine bay main fuse box and the front wing and remove any adhesive tape or dummy connector.
- 11 Connect the wiring harness to the four pole "Pre Acc" outlet.

Note

If the four pole "Pre Acc" outlet is already used, connect into the existing connector as follows

- Unplug "Pre Acc"
 - Remove the seal from the connector for the spotlight wiring harness and extract the lead.
 - Insert the cable into the connector that was plugged into "Pre Acc", position 3.
 - Plug in the connector to "Pre Acc".
- 12 Run the wiring harness through the hole for the headlamp and along the wiring harness towards the horn. Secure the spotlight wiring harness at the same fixing points as the horn wiring harness (5 off).

Important

The spotlight wiring harness must be placed adjacent to the horn wiring harness in the hole for the headlamp.

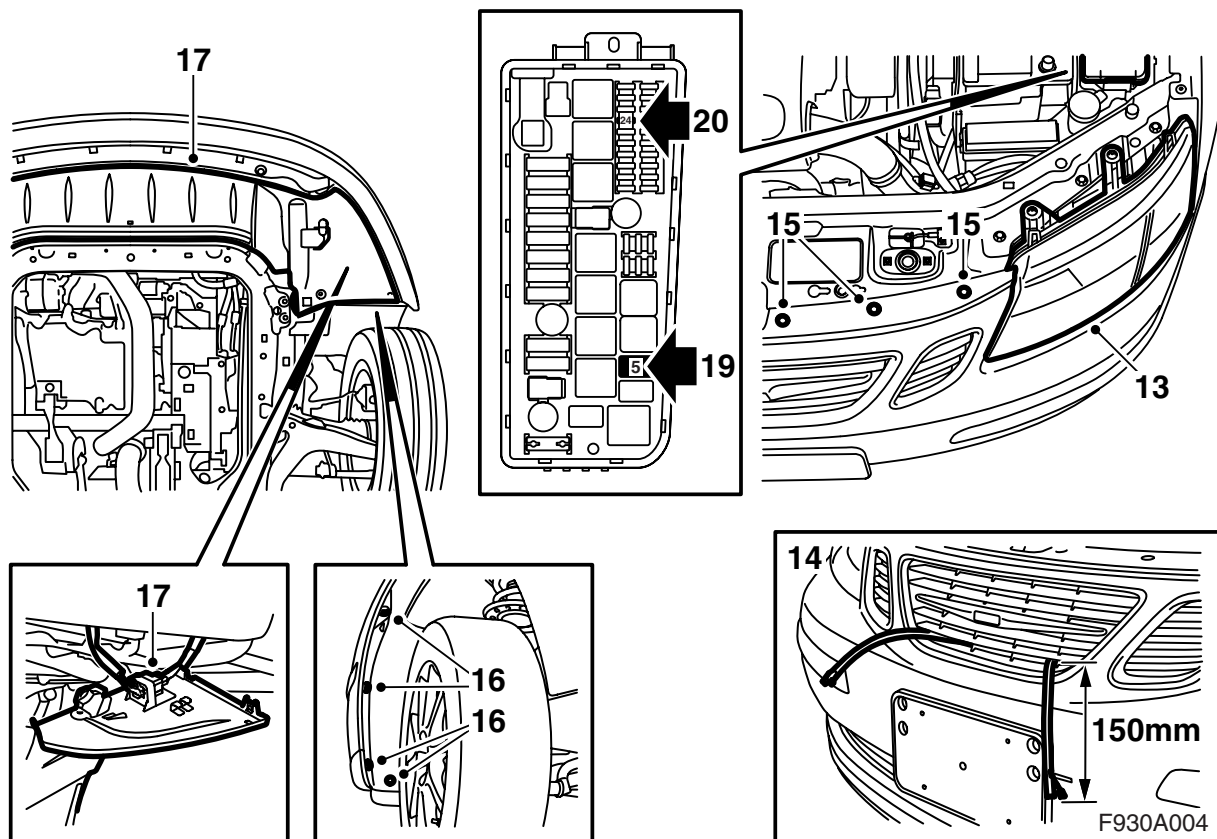

13 Connect and fit the headlamp.

14 Lift up the bumper.

Cars with headlamp washers: Connect the headlamp washer hose to the branching piece.

All: Position the bumper while inserting the spotlight wiring harness through the centre grille section. The wiring harness should protrude 150 mm from the grille. Press back the shell so that it fastens to the holder mounting.

WARNING

Check that the wiring harness is not pinched. Incorrect fitting can damage the wiring harness and cause a short-circuit/fire.

15 Mount the clips on the upper radiator member.

16 Raise the car and fit the bumper bolts into the wheel housing.

17 Lift up the spoiler shield, fit the bumper connector into the holder and plug in the connector.

Cars with headlamp washers: Hook the hose to the spoiler shield.

All: Fit the spoiler shield.

18 Lower the car and check the fit of the bumper.

19 Fit the relay into the engine bay main fuse box, position R5.

20 Fit the fuse into the engine bay main fuse box, position F24.

21 Connect the negative battery cable.

22 Adjust the time and date.

23 Synchronise remote control code by inserting the key into the ignition.

Important

Repeat this procedure with all keys. Otherwise, the remote controls will not function.

24 Activate window lift pinch protection function by operating the side windows up and down twice. An audible confirmation will sound when activation is complete.

25 Check the voltage to the spotlight connections. To activate the spotlights, the button on the dashboard marked “-” must be pressed.

26 **Cars with headlamp washers:** Check the function of the headlamp washers.

27 Connect the diagnostic tool, select car and model year, select “All”, select “Add/Remove”, select the accessory and then “Add”.

Note

The diagnostic tool will on some occasions need to retrieve a security code in TIS. Information on what to do will be displayed on the diagnostic tool display.

Wiring diagram

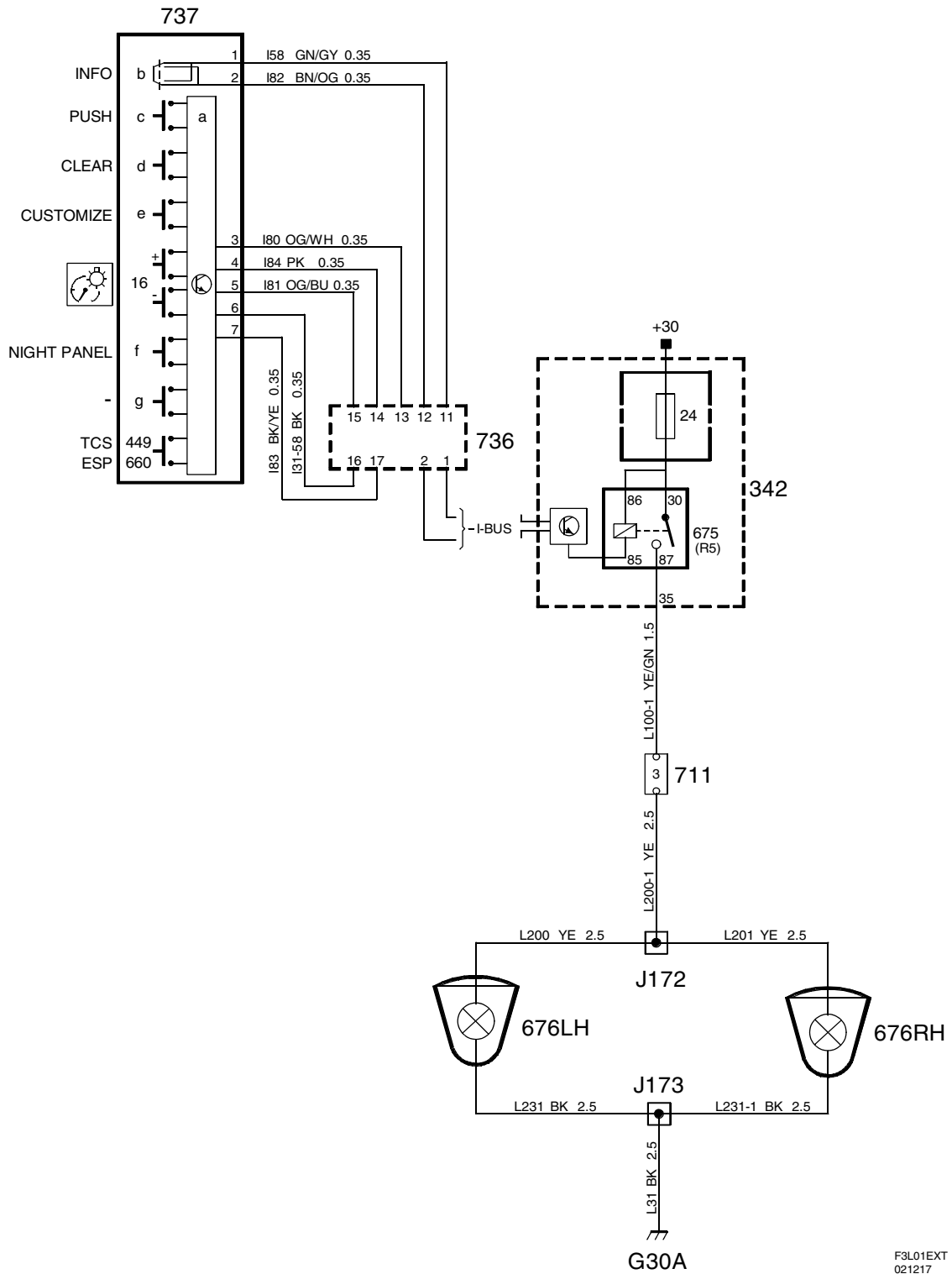

F3L01EXT
021217

List of components

No.	Name position
Components	
342	Electrical distribution unit, engine bay, next to the battery
675	Relay, spotlights, In the engine bay electrical distribution unit
676LH	Lamp, spotlight, left, in front of the grille
676RH	Lamp, spotlight, right, in front of the grille
711	Connector, accessories, in the engine bay near the left suspension strut housing
736	Control panel, infotainment, under the SID
737	Control panel, SID, on the dashboard next to the main instrument unit
Crimp connections	
J172	Approx. 400 mm from branching point grounding point G30A towards the spotlights
J173	Approx. 350 mm from branching point grounding point G30A towards the spotlights
Grounding points	
G30A	Front grounding point on the side plate above the left wheel housing